

Air Pressure Rocket Launcher

(Adapted from the NASA Aerospace Education Services Program’s lesson “Industrial Strength Paper Rockets” by Gregory Voght/ NASA JSC)

This launcher is used in conjunction with Micron K-12 Program’s “Forces in Motion: Rockets” lesson. It is available at: <http://www.micron.com/k12/lessonplans>

Parts List

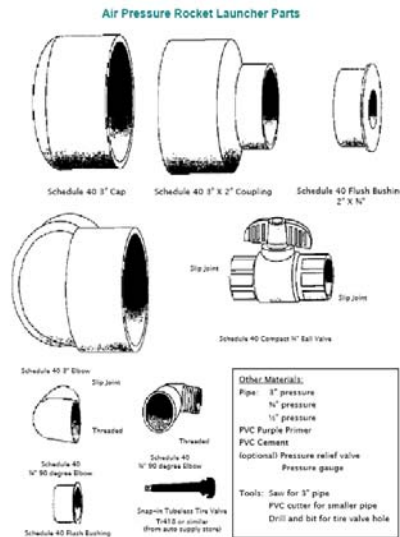

Launcher Diagram:

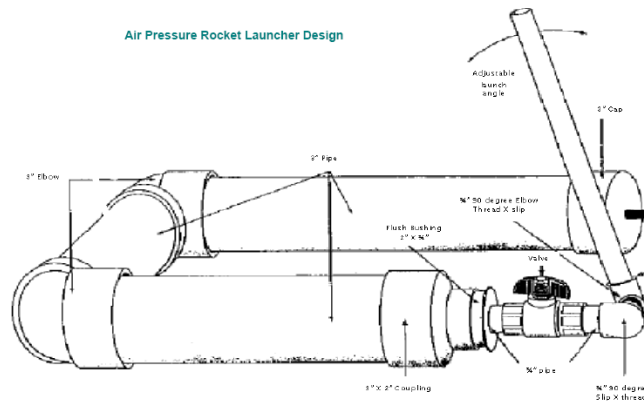

Constructing the Air Pressure Launcher

The air pressure launcher is made from Schedule 40 PVC plumbing parts available at most hardware stores. Refer to the “Parts” page for the specific parts needed. Clerks at the hardware store can help select the parts for you from the diagrams. Be sure to get pressure pipes for the 3”, 3/4” and 1/2” tubing.

Cut three pieces from the 3" pipe using a suitable saw. The pieces should be 17", 6" and 5" long. PVC cuts very easily. Remove any burrs from the cut and clean the pipe if it is dirty.

Using a drill and bit, drill a hole into the center of the 3" end cap. The size of the hole will depend upon the diameter of the tire valve stem. The hole should be just smaller than the diameter of the rubber stem so that the stem seals itself to the cap when it is pushed through the hole from the inside out.

Join the end cap to the 17-inch long 3" pipe segment with PVC cement. First clean both joining surfaces with PVC Purple Primer Cleaner. Make sure you are working in a well ventilated area away from open flame. When dry, coat the surfaces with PVC Cement and push the parts together immediately. Following the same cementing procedure, join one elbow to the other end of the pipe. Next, join the 5-inch long 3" pipe to the elbow. Join the remaining large elbow to the other end of this pipe segment. Be sure that both elbows are aimed in the same direction. The large tubes will serve as the launcher base and the pieces must not be twisted or the launcher will rock when it is being used. To insure proper alignment, set the base on the floor before the glue has set and press the second elbow until it is properly aligned.

Cement the 6-inch long 3" pipe to the elbow. Attach the 3"X2" Coupling and the 2" X 3/4" Flush Bushing with cement to the other end of the tube.

Cut two 2" long pieces of 3/4" tube and prepare them for cementing. Join one to the flush bushing on one end and to the valve on the other end. Cement the second tube to the other end of the valve.

Cement the 3/4" elbow (with outside threads on one end) to the end of the second small tube. Screw the second elbow on to the first. Do not cement this elbow. It needs to be able to be rotated.

Cement the 3/4" X 1/2" Flush Bushing into the open end of the second elbow.

Cut an 18-inch long piece of 1/2" pipe and push it into the elbow. It can be cemented if you wish. This is the launch tube.

For extra strength, wrap the tubes with nylon filament tape or duct tape. This is optional but recommended.

Constructing the Rocket Body Forms

The Rocket Body Forms are made from 12" sections of ½" PVC pipe. Cut the pipe into 12" lengths, and then use a file or sand paper to taper the upper end of the launch tube. This makes it easier to slip the rockets on and off of the launch tube.

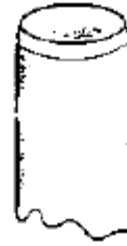

Rocket Launcher Options

- Launcher can be wrapped with nylon filament or duct tape. This will strengthen the PVC piping, and help make it less prone to failure.
- Launcher can be made with 2" PVC pipe if desired. Fittings will have to be sized down accordingly. This makes the launcher lighter and takes less time to pressurize it.
- A pressure gauge can be added to the assembly to monitor the pressure.
- A pressure relief valve can be added to the assembly (see picture). This prevents over-pressurizing the launcher, which can cause it to shatter.



Micron K12 Air Pressure Rocket Launcher
Constructed using 3" PVC pipe
Pressure gauge and relief valve added

Air Pressure Rocket Launcher Parts

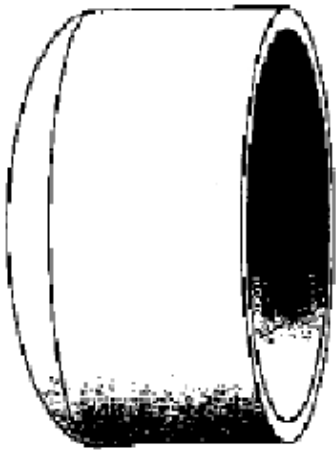

Schedule 40 3" Cap

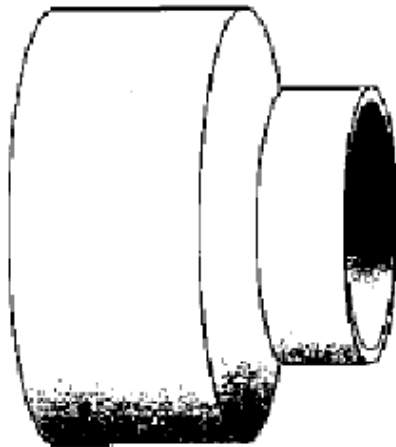

Schedule 40 3" X 2" Coupling



Schedule 40 Flush Bushing
2" X 3/4"

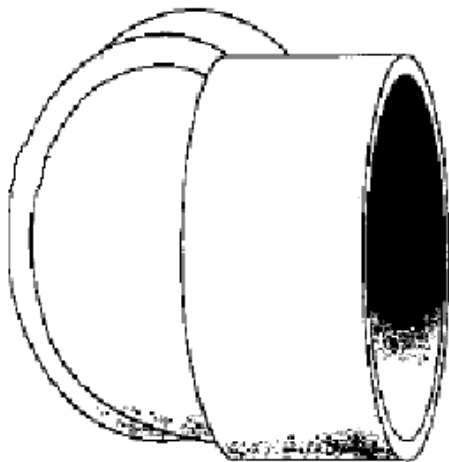

Schedule 40 3" Elbow

Slip Joint

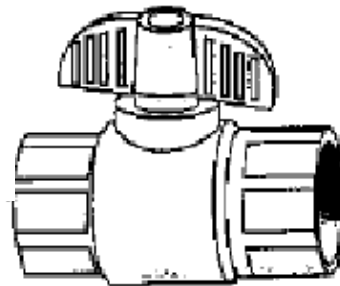

Slip Joint

Schedule 40 Compact 3/4" Ball Valve



Slip Joint

Schedule 40
3/4" 90 degree Elbow



Schedule 40 Flush Bushing
3/4" X 1/2"

Threaded



Threaded

Schedule 40
3/4" 90 degree Elbow



Snap-in Tubeless Tire Valve
Tr418 or similar
(from auto supply store)

Other Materials:

Pipe: 3" pressure
3/4" pressure
1/2" pressure

PVC Purple Primer

PVC Cement

(optional) Pressure relief valve

Pressure gauge

Tools: Saw for 3" pipe

PVC cutter for smaller pipe

Drill and bit for tire valve hole

Air Pressure Rocket Launcher Design

